

---

# SEALAND®

## FINE CHINA TOILET

### OWNER'S MANUAL

---

**Traveler® 500 *Plus* Series, 2000 Series, Traveler Lite® Toilets**



**Dometic Corporation**  
13128 State Rt 226, PO Box 38  
Big Prairie, OH 44611  
SeaLand Product Hotline 1-800-321-9886  
(8:00 a.m. - 5:00 p.m. ET)

---

## TABLE OF CONTENTS

---

Important Information .....	2	Troubleshooting Guide .....	6
Toilet Model Identification .....	2	100 Series Parts List .....	7
How to Use .....	2	500 <i>Plus</i> Series Parts List .....	8
Installation .....	3	2000 Series Parts List .....	9
Pedestal and Pedal Cover Installation .....	3	Dimensional Specifications .....	10
Proper Cleaning and Maintenance .....	4	Ordering Parts .....	11
Winterizing .....	4	Parts Distributors .....	11
Deodorants and Special Tissue .....	5	Manufacturer's Limited Warranties .....	12
Service Tip .....	5		

---

## IMPORTANT INFORMATION

---

1. Do not use chlorine or caustic chemicals, such as laundry bleach or drain opening types, in the system. These products damage the seals in toilets and dump valves.
2. Do not permit foreign objects (paper towels, paper cups, diapers, sanitary napkins, etc.) to be flushed through the toilet.
3. Mechanical seal toilets, like SeaLand Traveler units, are designed to only discharge directly into a holding tank.  
Horizontal pipe runs as found in conventional residential or commercial plumbing systems cannot be accommodated.
4. Toilet bowl and flush seals must be regularly cleaned and winterized according to "Proper Cleaning and Maintenance" and "Winterizing" procedures on page 4, or your warranty coverage may be voided.

---

## TOILET MODEL IDENTIFICATION

---

The model identification label is located on the toilet base and will show the model number and serial number. Follow instructions for removing toilet pedestal cover in "Pedestal and Pedal Cover Installation" on page 3. Traveler Lite Model 110 identification label is on the back of the base. If label is not available, please refer to "Dimensional Specifications" on page 10 for toilet model identification.

### DOMETIC CORPORATION

P.O. BOX 38, 13128 STATE RT 226 (800) 321-9886  
BIG PRAIRIE, OH 44611 USA

MODEL NO. **000**

SERIAL NUMBER

**000000**

---

## HOW TO USE

---

To prepare the Traveler toilet for use, check to be sure water supply to the toilet is connected. Turn on water supply and check system for leaks. Flush toilet and check for leaks.

To properly use the Traveler toilet, follow these simple instructions:

1. **To add water to the toilet**, lift or raise the flush lever until desired water level is reached.  
Generally, more water is required only when flushing solids.
2. **To flush toilet**, push lever all the way down until contents leave toilet bowl. Water flow pressures vary at different locations, therefore holding the flush lever down for 4-8 seconds may be required. We require a minimum flow to the toilet of two gpm (7.6 lpm) for proper rim and bowl wash.
3. Release flush lever by allowing it to snap back, which permits positive sealing around the flush ball.
4. A small amount of water should remain in bowl.



**Note: Holding flush lever down longer than necessary results in excessive water usage.**

# INSTALLATION

1. To replace an older toilet, turn off water supply to toilet. Disconnect water line at toilet water valve. Unscrew floor bolt nuts and remove toilet. Discard old floor seal and mounting bolts. The old floor flange may be used if it is in good condition and has four (4) bolt locations. [Only two bolts are required for Traveler Lite Model 110.]

**NOTE: If old floor flange cannot be used and cannot be removed, please use a SeaLand Universal Mounting Kit, available from your SeaLand dealer.**

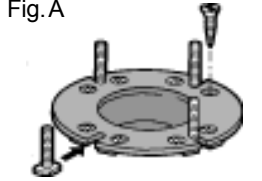
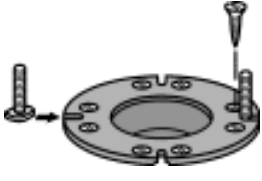
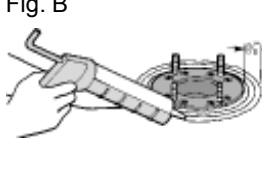
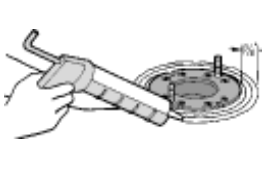
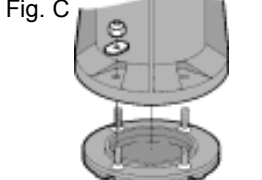
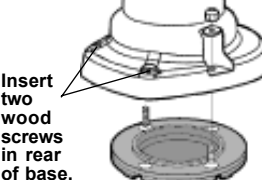
2. When installing new floor flange, make certain that the toilet mounting bolts align properly with Traveler toilet mounting pattern.
3. Secure flange to floor using flat head screws through countersunk holes in flange. Insert floor bolts into slotted holes in flange (Figure A).
4. If toilet is being installed in a shower stall, apply a 1/4" thick by 3/4" wide bead of glazing compound around the circumference of the floor flange (Figure B).
5. Install seat assembly with hinges and screws provided. Traveler Models 510/511 will also accept handicap or household decorative seats. [Traveler Lite Models 110/111 seats are already installed.]
6. Position floor seal by pressing the floor bolts up through holes in the seal.
7. Set toilet in place with bolts protruding up through mounting holes in base (Figure C).
8. Install washers and hex nuts provided with toilet. Snug nuts down equally with standard 7/16" open end wrench. Remove excess glazing compound from around base in shower stall installation. For Traveler Lite Model 110, also install two wood screws provided in two holes at rear of base. (See Figure C).
9. Connect water supply line to water valve (1/2" MPT) inlet using appropriate fittings or an extension (Figure D). For Traveler Lite Model 110, you must remove water valve cover from flush pedal before connecting water supply line (see instructions below).

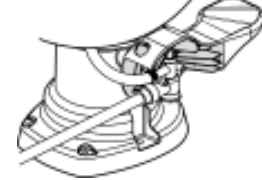
All Traveler toilets and Traveler Lite Model 111 (4-bolt connection)	Traveler Lite Model 110 (2-bolt connection)
Fig. A 	
Fig. B 	
Fig. C 	
Fig. D 	

10. Turn on water supply and flush toilet to test for leaks.
11. For all models except Traveler Lite Model 110, attach pedestal and pedal covers to toilet base (see installation instructions below).

## PEDESTAL AND PEDAL COVER INSTALLATION

### ALL TRAVELER TOILETS AND TRAVELER LITE MODEL 111:



1. Wrap pedestal cover around base so that it closes as shown.

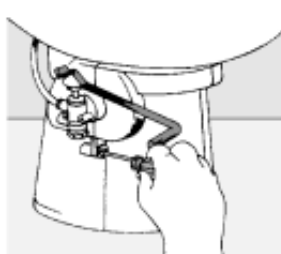

2. Tall model – screw cover together. Short model – snap together.

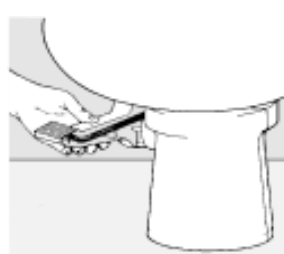

3. Slide pedal cover onto foot pedal rod.

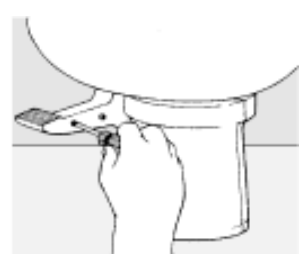

4. Secure side plate onto pedal cover with screws.

### TRAVELER LITE MODEL 110:

1. Press button on back of pedal to release water valve cover.

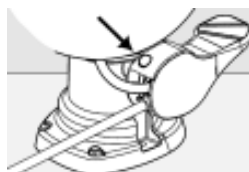

2. Pull on bottom of cover to remove it. Cover snaps back into place.

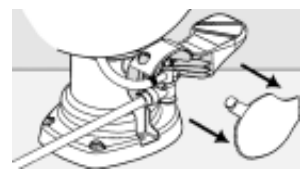

---

## PROPER CLEANING AND MAINTENANCE

---

The Traveler toilet should be cleaned regularly for maximum sanitation and operational efficiency. You can clean it just as you would a household toilet. **Do not use caustic chemicals, such as drain-opening types, as they will damage the seals.**

**BOWL CLEANING:** For stubborn stains, use SeaLand® Bowl and Seal Cleaner (Fig. A). It's manufactured especially for use with Traveler and Traveler Lite toilets. In certain locations where water is hard, a build-up of lime may dull the toilet bowl finish. Restore the shine with this SeaLand cleaner. If you cannot find it in your area, contact SeaLand for your nearest dealer. If the cleaner is not available, you can also use Bar Keepers Friend® cleanser. It is not necessary to vigorously scrub with either product. Please follow label instructions.

**SEAL CLEANING:** After an extended time, mineral deposits from hard water can build up under the edge of the rubber bowl seal, resulting in a slow leakdown of water from the bowl. To prevent this mineral build-up, periodically clean under the bowl seal with SeaLand Bowl and Seal Cleaner (Fig. B).

1. Shut off water supply.
2. Apply cleaner onto a cleaning brush, open the flush ball by pressing on flush lever, and scrub under the seal. Make sure to push brush bristles between bottom of seal and top of flush ball surface to scrub all parts of seal that come into contact with flush ball.
3. Close ball and wait 2-3 minutes.
4. Open flush ball. Use brush and water to rinse away cleanser and loosened deposits.



Fig. A

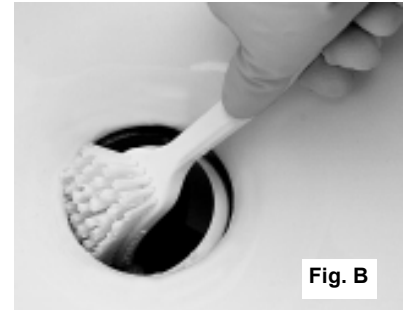

Fig. B

---

## WINTERIZING

---

At the end of each season, the Traveler or Traveler Lite toilet should be winterized for storage, by either draining or using potable water-safe antifreeze in the system.

**To drain:**

1. Thoroughly flush system with fresh water.
2. Empty holding tank.
3. Shut off water supply to toilet(s), and remove inlet waterline (Fig. C).  
**Do not remove brass cap on bottom of valve.**
4. Press flush lever until all water is drained from toilet(s).

**To use antifreeze:**

1. Drain potable water tank.
2. Add freshwater antifreeze to potable water tank.
3. Flush potable water antifreeze and water mixture through toilet(s) and into the waste holding tank. Each installation is different, so amounts may vary. User discretion is required to assure adequate protection.
4. Empty holding tank.

**NOTE:** Use nontoxic antifreeze designated for potable water systems. (See vehicle owner's manual.)

**CAUTION:** Never use automotive-type antifreeze in freshwater systems.

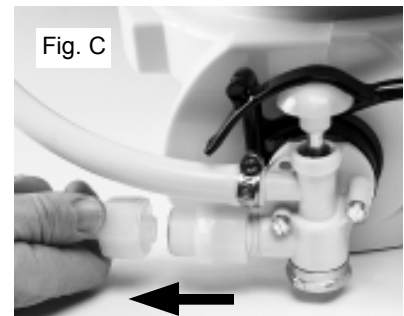

Fig. C

---

## DEODORANTS AND SPECIAL TISSUE

---

Your Traveler toilet requires the regular addition of a deodorant product to reduce malodors and to help break down holding tank contents. Several factors should be considered in selecting a deodorant product.

**Liquid or Granulated:** Liquid products obviously work more quickly by readily going into solution. Granulated powder formulations, on the other hand, have the advantage of requiring less storage space and are less likely to leak if the package is inadvertently damaged.

**Formaldehyde versus Non-Formaldehyde:** Dometic manufactures both types of deodorants. Generally speaking, formaldehyde formulas control odor very effectively at all temperatures and with all degrees of water hardness. SeaLand® Environment-Friendly brand, which is formaldehyde free, is similarly effective.

**How Much Deodorant and How to Add It:** The deodorant is added directly into the toilet bowl, then flushed into the holding tank. Follow bottle or package instructions. Conditions of extremely warm weather, longer waste holding time and larger tank capacities may require more deodorant treatment. Also, to maintain optimum efficiency in odor control, the waste holding tank should be cleaned thoroughly at least once or more each season depending on use.

**Why Not Use Household Toilet Paper in Your Traveler Toilet.** Household tissues often contain adhesives which bond together the paper fibers from which the tissue is made. The adhesives prevent the tissue from breaking apart, and their use in “ultra-low flow” systems can cause system clogging. SeaLand tissue is especially designed for use in low water toilet systems. Its rapid dissolving properties minimize the amount of residual paper in the holding tank and allow deodorizers to work more efficiently.

**SeaLand Brand versus Other Brands:** We constantly strive to provide our system owners with effective products that have minimal environmental impact and good value. Many deodorant products do not measure up to our standards of performance and value.

### SeaLand® Granulated Deodorant

Six 2-oz. pouches



Part No.  
379626002

### SeaLand® Liquid Deodorant

Two 8-oz. bottles

Part No.  
379224008



SeaLand®  
Cleaner  
16-oz. bottle  
Part No.  
379314016

### SeaLand® Liquid Deodorant - Environment Friendly

32-oz. bottle

Part No.  
379114032



SeaLand®  
Rapid-Dissolving  
Toilet Tissue  
Four 400-sheet rolls  
Part No. 379441204

---

## SERVICE TIP

---

Checking for water leaks behind or under toilets or other appliances can make it difficult to locate the source. Dripping water at room temperature makes it difficult to feel wetness. Taking four or five sheets of toilet tissue and wiping all seams and waterline connections offers a simple means of locating the general area of the leakage. Start at the top of the unit since gravity will cause a leak to run downward. When the tissue comes in contact with the leaking water, it will immediately change texture.

# TROUBLESHOOTING GUIDE

## BASE ASSEMBLY

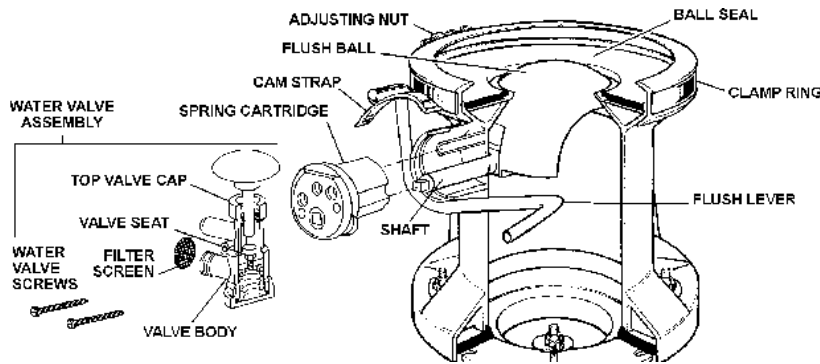

## REAR VIEW, TOILET

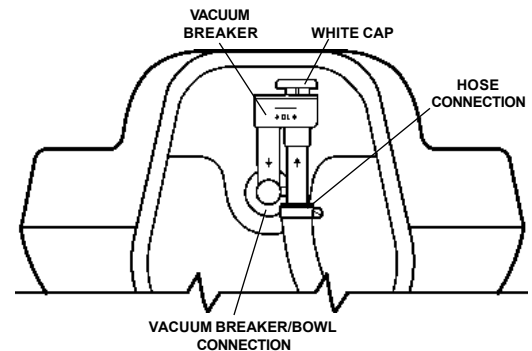

Problem	Possible Cause	Service Instructions
1. Toilet emits odor (flush ball open).	<ul style="list-style-type: none"> <li>a. Odor emitting from base of toilet.</li> <li>b. Plugged holding tank vent line.</li> </ul>	<ul style="list-style-type: none"> <li>a. Use SeaLand brand deodorants.</li> <li>b. Clear obstructions from vent line.</li> </ul>
2. Water will not stay in bowl.	<ul style="list-style-type: none"> <li>a. Loose clamp ring.</li> <li>b. Improper seal around flush ball due to dirt or debris on underside of ball seal.</li> <li>c. Worn or damaged ball seal.</li> <li>d. Worn or damaged flush ball.</li> </ul>	<ul style="list-style-type: none"> <li>a. Tighten clamp ring adjusting nut.</li> <li>b. Inspect flush ball and underside of seal for foreign objects. Clean under seal if needed (cleaning tool available – p/n 600344236).</li> <li>c. Replace ball seal.</li> <li>d. Replace flush ball.</li> </ul>
3. Plastic flush ball will not close completely.	<ul style="list-style-type: none"> <li>a. Too much friction between flush ball and ball seal.</li> <li>b. Water valve screws are too tight.</li> <li>c. Defective spring cartridge.</li> </ul>	<ul style="list-style-type: none"> <li>a. Lubricate between flush ball and ball seal with furniture polish or cooking spray.</li> <li>b. Loosen screws slightly.</li> <li>c. Check spring tension by pushing flush lever down, then release it suddenly. If lever does not snap back into original position, replace spring cartridge.</li> </ul>
4. Flush ball will not open.	<ul style="list-style-type: none"> <li>a. Broken shaft.</li> <li>b. Shaft not fully engaged in the spring cartridge.</li> </ul>	<ul style="list-style-type: none"> <li>a. Replace shaft.</li> <li>b. Put pressure on shaft from under the flush ball (pushing into spring cartridge) until it engages. You may have to rotate flush ball slightly until shaft lines up with square in spring cartridge.</li> </ul>
5. Flush ball does not open completely. <b>Low-profile units only.</b>	<ul style="list-style-type: none"> <li>a. Floor flange interferes with flush ball.</li> </ul>	<ul style="list-style-type: none"> <li>a. Loosen mounting bolts and center toilet over floor flange. Replace floor flange with one of the following models: 385345889 3-inch MPT; 385345892 3-inch socket; 385343765 3-inch spigot</li> </ul>
6. Water does not shut off in toilet (toilet overflows).	<ul style="list-style-type: none"> <li>a. Not enough clearance between cam strap and top of water valve cap.</li> <li>b. Dirt lodged in water valve seal.</li> </ul>	<ul style="list-style-type: none"> <li>a. Adjust cam strap to have .02" (.5mm) minimum clearance with top of valve cap.</li> <li>b. Dissassemble and clean water valve.</li> </ul>
7. Hand spray unit leaks.	<ul style="list-style-type: none"> <li>a. Hand sprayer is defective.</li> </ul>	<ul style="list-style-type: none"> <li>a. Replace hand sprayer.</li> </ul>
8. Water does not enter toilet bowl properly.	<ul style="list-style-type: none"> <li>a. Insufficient water flow rate at toilet.</li> <li>b. Water valve clogged.</li> <li>c. Plugged rim wash holes in toilet.</li> </ul>	<ul style="list-style-type: none"> <li>a. Check water flow rate at toilet. Rate should be 2 gpm (7.6 lpm) at toilet.</li> <li>b. Remove and clean screen located inlet of water valve.</li> <li>c. Clean holes. If still a problem, replace the toilet bowl.</li> </ul>
9. Water leaking from water valve.	<ul style="list-style-type: none"> <li>a. Water valve body cracked due to freeze damage.</li> <li>b. Water line connection is loose or not seated properly.</li> <li>c. Defective water valve.</li> <li>d. Stripped threads.</li> </ul>	<ul style="list-style-type: none"> <li>a. Replace water valve.</li> <li>b. Insure that threads are not cross-threaded and tighten.</li> <li>c. Replace water valve.</li> <li>d. Replace water valve.</li> </ul>
10. Water leaking from bottom of toilet base.	<ul style="list-style-type: none"> <li>a. Toilet loose.</li> <li>b. Worn or defective toilet mounting floor seal.</li> <li>c. Cracked base.</li> <li>d. Worn or defective floor flange.</li> </ul>	<ul style="list-style-type: none"> <li>a. Tighten toilet mounting bolts.</li> <li>b. Replace floor seal between floor flange and toilet base.</li> <li>c. Replace base assembly.</li> <li>d. Replace floor flange.</li> </ul>
11. Water leaking from rear of toilet bowl.	<ul style="list-style-type: none"> <li>a. Worn or defective vacuum breaker.</li> <li>b. Cracked or defective toilet bowl.</li> <li>c. Flush ball interferes with floor flange.</li> </ul>	<ul style="list-style-type: none"> <li>a. Remove white cap from vacuum breaker. Flush toilet. If water leaks during flush, vacuum breaker needs to be replaced.</li> <li>b. Secure vacuum breaker connection.</li> <li>c. Replace toilet bowl.</li> </ul>

# TRAVELER LITE® PARTS LIST

## MODEL 111

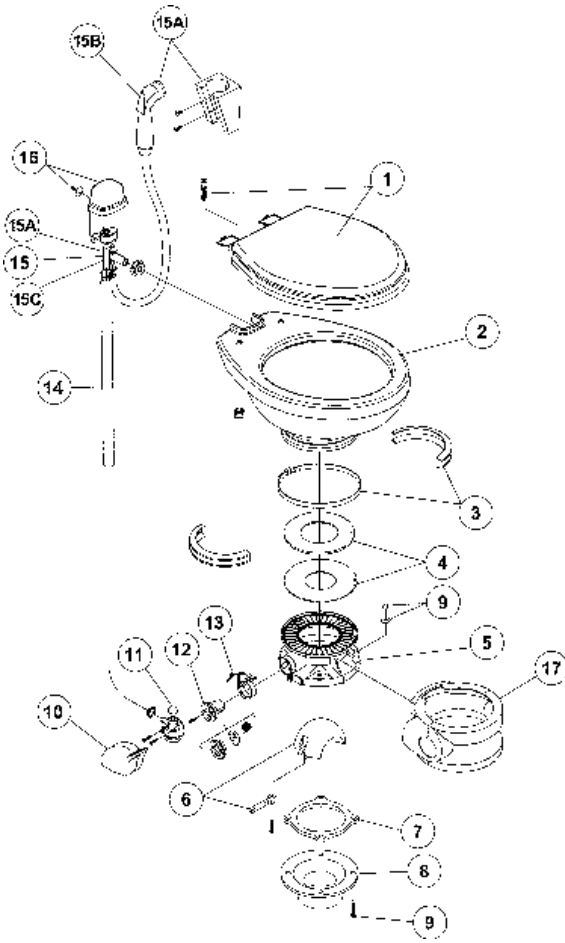

## MODEL 110

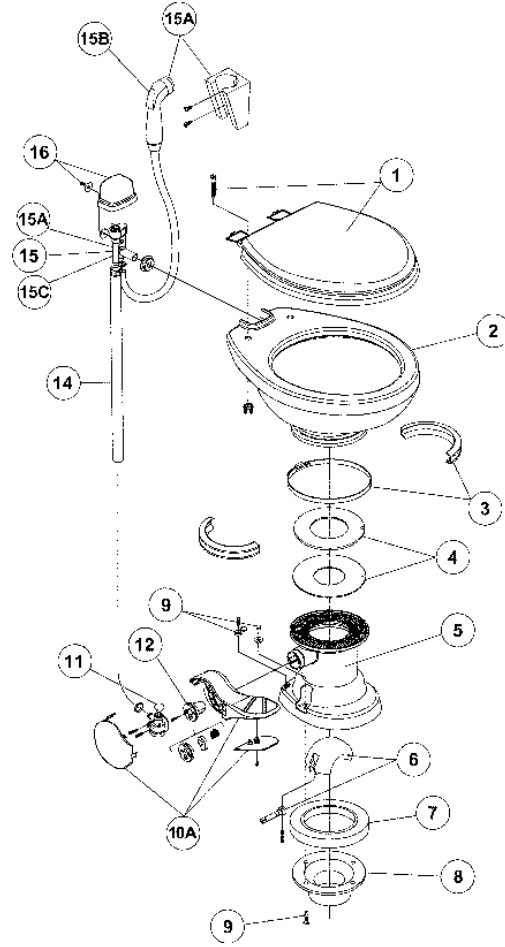

Item	111	110	Description	Item	111	110	Description	
1	385344088	385344088	Seat Assembly, White	9	385310064	385310794	Floor Bolt Mounting Kit	
	385344089	385344089	Seat Assembly, Bone				Floor Bolt Mounting Kit, White	
2	385310790	385310790	China Bowl Kit, White	10	385310117	385310803	Floor Bolt Mounting Kit, Bone	
	385310791	385310791	China Bowl Kit, Bone				Pedal Cover Kit, White	
3	385310048	385310025	Ring & Half Clamp Kit, White	10A		385310682	Pedal Cover Kit, Bone	
		385310048	Ring & Half Clamp Kit, Bone				Flush Pedal Kit, White (incl. 12)	
4	385316140	385316140	Teflon® & Rubber Seal Kit			385310762	Flush Pedal Kit, Bone (incl. 12)	
5	385310801	385310792	Base Kit, White (includes 3, 4, 6, 7, 9, 10A, 11, 12)	11	385314349	385314349	Water Valve Kit	
		385310793	Base Kit, Bone (includes 3, 4, 6, 7, 9, 10A, 11, 12)	12	385236096	385310683	Spring Cartridge Kit	
			Base Kit, White (includes 3, 4, 6, 7, 9, 10, 11, 12, 13, 17)	13	600340825			Flush Lever
		385310802	Base Kit, Bone (includes 3, 4, 6, 7, 9, 10, 11, 12, 13, 17)	14	600340177	600340177		Supply Hose, Bone
6	385318162	385310681	Ball, Shaft & Cartridge Kit	15	385310687	385310687	Vacuum Breaker Kit	
7	600341549	600343938	Floor Flange Seal	15A	385319054	385319054	Vacuum Breaker Kit w/ Spray	
8	385345889	385345889	Floor Flange Adapter, 3" MPT (sold separately)	15B	600340683	600340683	Hand Spray, White	
	385345892	385345892	Floor Flange Adapter, 3" Socket (sold separately)	15C	385230335	385230335	Vacuum Breaker (used w/ Spray)	
	385343765	385343765	Floor Flange Adapter, 3" Spigot (sold separately)	16	385310795	385310795	Vacuum Breaker Cover Kit, White	
					385310796	385310796	Vacuum Breaker Cover Kit, Bone	
				17	385310108		Pedestal Cover Kit, White	
					385310109		Pedestal Cover Kit, Bone	

# 500 PLUS SERIES PARTS LIST

## MODEL 511+

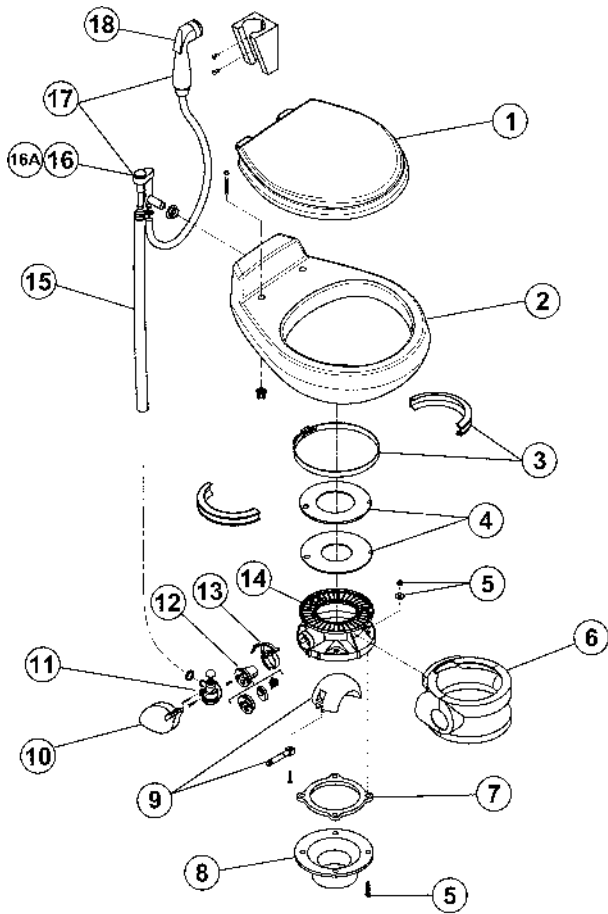

## MODEL 510+

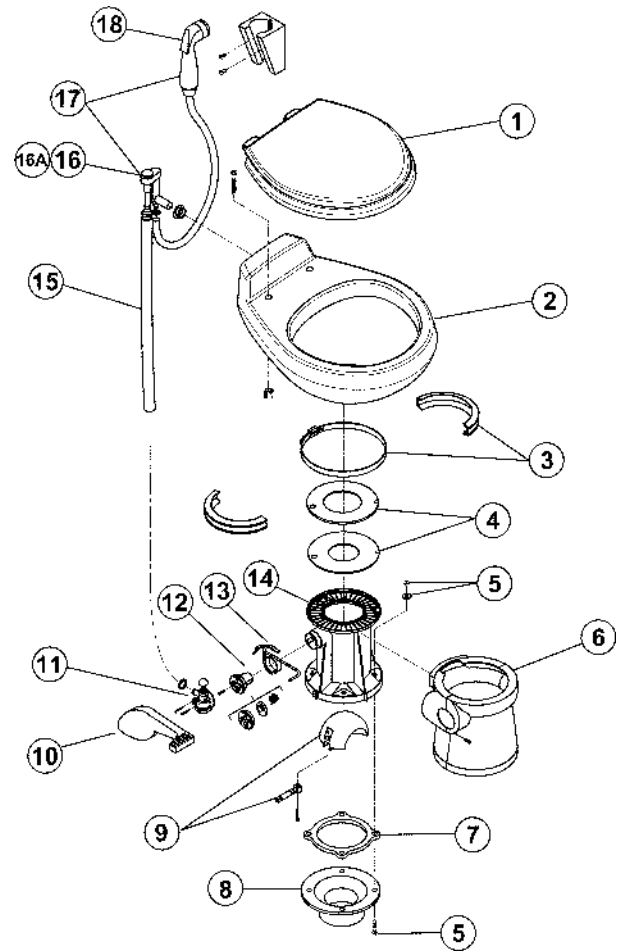

Item	511+	510+	Description	Item	511+	510+	Description	
1	385343829	385343829	Seat Assembly, White	9	385318162	385318162	Ball/Shaft/Cartridge Kit, White/Bone/Platinum	
	385343831	385343831	Seat Assembly, Bone		385310177	385310177	Ball/Shaft/Cartridge Kit, Ebony	
	385343897	385343897	Seat Assembly, Platinum		385310188	385310188	Ball/Shaft/Cartridge Kit, Teal	
	385343901	385343901	Seat Assembly, Ebony		10	385310117	385310114	Pedal Cover Kit, White
	385343899	385343899	Seat Assembly, Teal			385310118	385310115	Pedal Cover Kit, Bone
2	385310739	385310739	China Bowl Kit, White	385310119	385310116	Pedal Cover Kit, Platinum		
	385310740	385310740	China Bowl Kit, Bone	385310593	385310175	Pedal Cover Kit, Ebony		
	385310741	385310741	China Bowl Kit, Platinum	385310596	385310193	Pedal Cover Kit, Teal		
	385310742	385310742	China Bowl Kit, Ebony	11	385314349	385314349	Water Valve Kit	
	385310743	385310743	China Bowl Kit, Teal		12	385236096	385236096	Spring Cartridge Assembly
3	385310048	385310048	Ring & Half Clamp Kit	13	600340825	600340873	Flush Lever	
4	385316140	385316140	Teflon® & Rubber Seal Kit		385310744	385310578	Flush Lever/Spring Cartridge Ass'y.	
5	385310064	385310064	Mounting Bolt Kit	14 *	385310123	385310120	Base Kit, White	
6	385310108	385310111	Pedestal Cover Kit, White		385310124	385310121	Base Kit, Bone	
	385310109	385310112	Pedestal Cover Kit, Bone		385310125	385310122	Base Kit, Platinum	
	385310110	385310113	Pedestal Cover Kit, Platinum		385310588	385310169	Base Kit, Ebony	
	385310600	385310173	Pedestal Cover Kit, Ebony		385310620	385310198	Base Kit, Teal	
	385310603	385310203	Pedestal Cover Kit, Teal	15	600340177	600340177	Supply Hose	
7	600341549	600341549	Floor Flange Seal	16	385316906	385316906	Vacuum Breaker Kit	
8	385345889	385345889	Floor Flange, 3" MPT (sold separately)	16A	385230335	385230335	Vacuum Breaker Kit (used with Hand Spray)	
	385345892	385345892	Floor Flange, 3" Socket (sold separately)		17	385319054	385319054	Vacuum Breaker w/ Hand Spray Kit
	385343765	385343765	Floor Flange, 3" Spigot (sold separately)		18	600340683	600340683	Hand Spray, White
					600341770	600341770	Hand Spray, Ebony	

\* includes items 3 - 7, 9 - 13

# 2000 SERIES PARTS LIST

## MODEL 2011

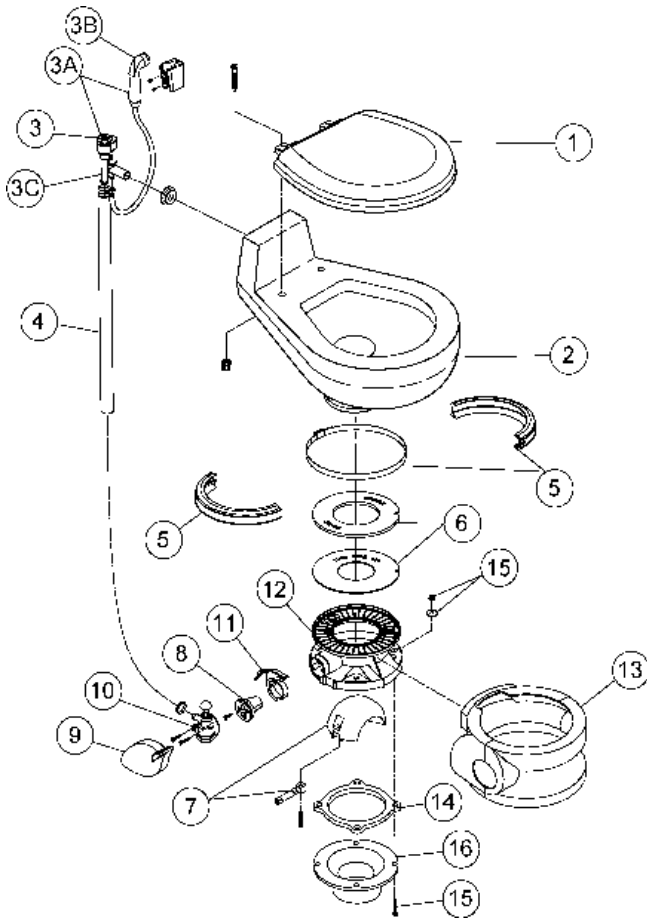

## MODEL 2010

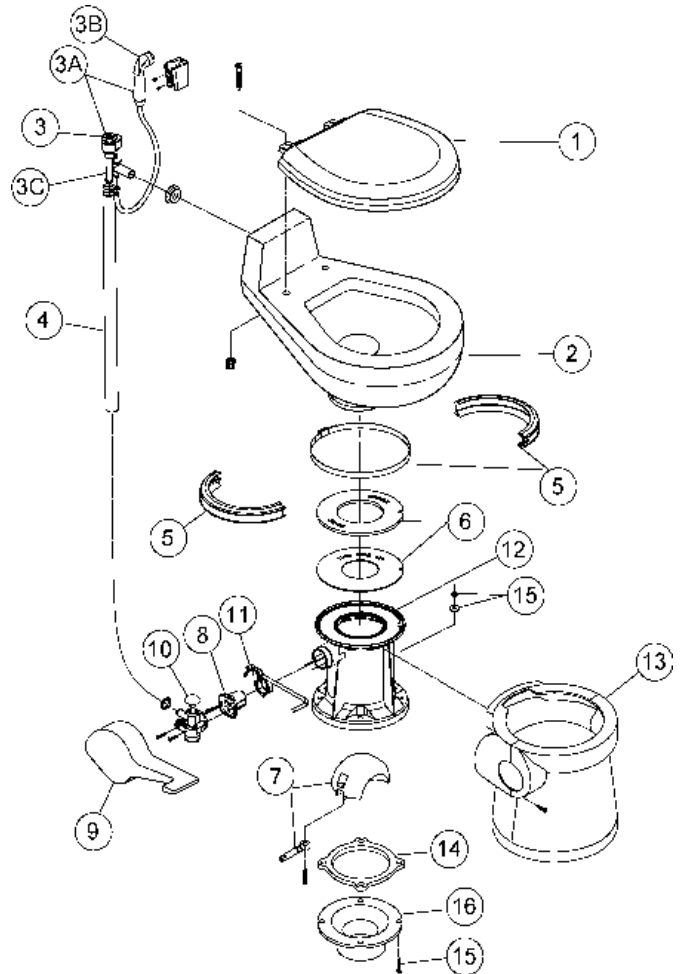

Item	2011	2010	Description	Item	2011	2010	Description
1	385344436 385344437 385344438	385344436 385344437 385344438	Seat Assembly, White Seat Assembly, Bone Seat Assembly, Ebony	10	385314349	385314349	Water Valve Kit
2	385310615 385310616 385310585	385310615 385310616 385310585	China Bowl Kit, White China Bowl Kit, Bone China Bowl Kit, Ebony	11	600340825 385310579	600340873 385310578	Flush Lever Flush Lever & Spring Cartridge Kit
3	385316906	385316906	Vacuum Breaker Kit	12*	385310123 385310124 385310588	385310120 385310121 385310169	Base Kit, White Base Kit, Bone Base Kit, Ebony
3A	385319054	385319054	Vacuum Breaker with Spray Kit	13	385310108 385310109 385310600	385310111 385310112 385310173	Pedestal Cover Kit, White Pedestal Cover Kit, Bone Pedestal Cover Kit, Ebony
3B	600340683 600341770	600340683 600341770	Hand Spray, White Hand Spray, Ebony	14	600341549	600341549	Floor Flange Seal
3C	385230335	385230335	Vacuum Breaker (used with Hand Spray)	15	385310064	385310064	Mounting Bolt Kit
4	600340177	600340177	Supply Hose, Bone	16	385345889 385345892 385343765	385345889 385345892 385343765	Floor Flange, 3" MPT (sold separately) Floor Flange, 3" Socket (sold separately) Floor Flange, 3" Spigot (sold separately)
5	385310048	385310048	Ring & Half Clamp Kit				
6	385316140	385316140	Teflon® & Rubber Seal Kit				
7	385318162 385310177	385318162 385310177	Ball/Shaft/Cartridge Kit, White/Bone Ball/Shaft/Cartridge Kit, Ebony				
8	385236096	385236096	Spring Cartridge Assembly				
9	385310117 385310118 385310593	385310114 385310115 385310175	Pedal Cover Kit, White Pedal Cover Kit, Bone Pedal Cover Kit, Ebony				

# DIMENSIONAL SPECIFICATIONS

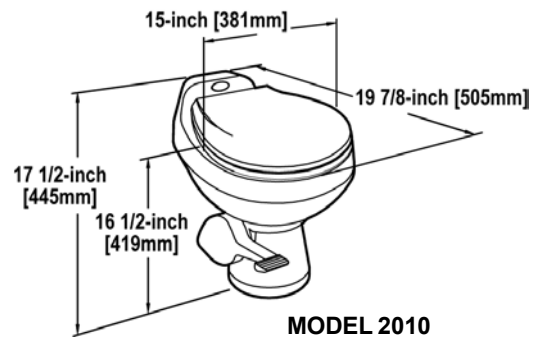
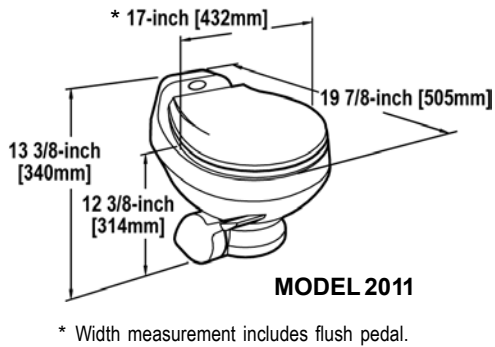
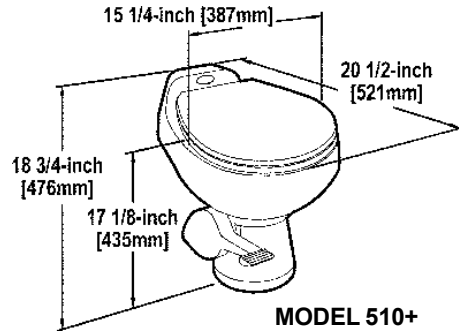
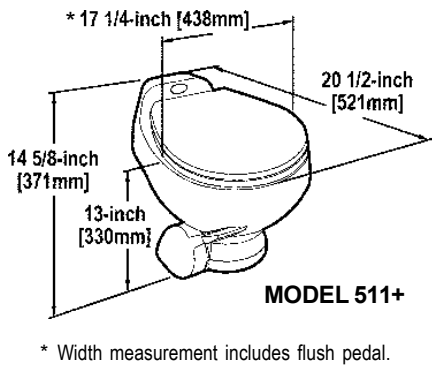
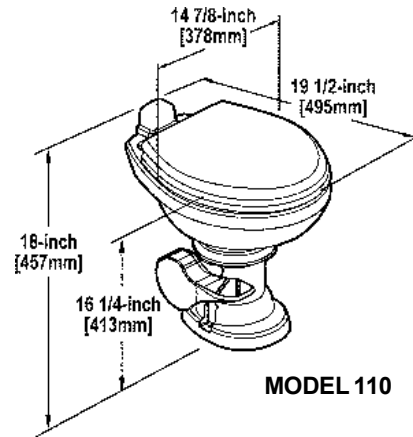
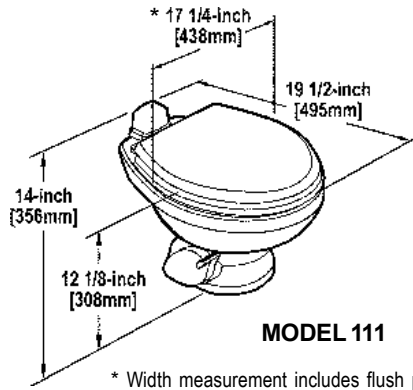

All dimensions may vary  $\pm$  3/8-inch (10mm).

---

## ORDERING PARTS

---

Dometic is ready to assist you in the event service is required. Before calling, please have the following information available. Your cooperation in having this information ready is appreciated and allows us to better meet your needs.

1. Toilet Model Number
2. Serial Number
3. Part Number, Description and Quantity (See Parts List.)

---

## PARTS DISTRIBUTORS

---

We have a strong, worldwide network to assist in servicing and maintaining your Traveler toilet. For the name of an Authorized Service Center near you, please call from 8:00 a.m. to 5:00 p.m. (Eastern Time) Monday through Friday. Or e-mail us at [sealand@dometicus.com](mailto:sealand@dometicus.com).

**Telephone: 1-800-321-9886 USA and Canada**

**330-496-3211 International**

**Fax: 330-496-3097 USA and Canada**

**330-496-3220 International**

You can also contact or have your local dealer contact the Parts Distributor in your area for quick response to your replacement parts needs. They carry a complete replacement parts inventory for this SeaLand product line.

### U.S.A. MASTER SANITATION DISTRIBUTORS

#### U.S.A. – North Central (IL, IN, KY, MI, OH)

Midwest Marine Supply  
24300 Jefferson Ave.  
St. Clair Shores, MI 48080  
Tel: 586-778-8950  
800-860-1540  
Fax: 586-778-6108  
Email: [midwestmarine@yahoo.com](mailto:midwestmarine@yahoo.com)  
Contact: Bob Kennedy

#### U.S.A. - Northeast (CT, DE, DC, MA, MD, ME, NH, NJ, NY, PA, RI, VA, VT, WV)

Northeast Marine Sanitation  
69 Florida Street  
Farmingdale, NY 11735  
Tel: 631-752-7606  
800-352-4323  
Fax: 631-752-7615  
888-283-7606  
E-mail: [northeast@northeast sanitation.com](mailto:northeast@northeast sanitation.com)  
Contact: Mike Starito

#### U.S.A. - Northwest (AK, ID, MT, OR, WA, WY)

Marine Sanitation, Inc.  
1900 N. Northlake Way, Suite 121  
Seattle, WA 98103  
Tel: 206-633-1110  
800-624-9111  
Fax: 206-633-0317  
E-mail: [marinesan@mindspring.com](mailto:marinesan@mindspring.com)  
Contact: Ric Kolb

#### U.S.A. - South Central (AR, KS, LA, MO, MS, NM, OK, TX)

AER Supply  
P.O. Box 349  
2301 Nasa Road #1  
Seabrook, TX 77586  
Tel: 281-474-3276  
800-767-7606  
Fax: 281-474-2714  
E-mail: [rsmiller@aersupply.com](mailto:rsmiller@aersupply.com)  
Contact: Richard Miller

#### U.S.A. - Southeast (AL, FL, GA, NC, PR, SC, TN, VI)

Environmental Marine Service  
111 S.W. 23rd Street, Suite A  
Fort Lauderdale, FL 33315  
Tel: 954-522-2626  
800-522-2656  
Fax: 954-522-5152  
E-mail: [info@environmentalmarine.com](mailto:info@environmentalmarine.com)  
Contact: John or Jill Hopkins

#### U.S.A. - Southwest (AZ, CO, NV, UT, CA-south)

Ardemco Marine Specialties  
778 West 17th Street  
Costa Mesa, CA 92627  
Tel: 949-722-7672  
800-253-0115  
Fax: 949-642-9582  
E-mail: [ardemco@earthlink.net](mailto:ardemco@earthlink.net)  
Contact: Rick Glasser

#### U.S.A. – Upper Midwest (IA, MN, ND, NE, SD, WI)

PowerHouse Marine  
518 Logan  
La Crosse, WI 54603  
Tel: 608-784-9580  
888-752-4539  
Fax: 608-784-8422  
E-mail: [dave@powerhousemarine.com](mailto:dave@powerhousemarine.com)  
Contact: Dave Tucker

#### U.S.A. – Northern California

Fox Marine  
2250 Zanker Road, Unit D  
San Jose, CA 95131  
Tel: 408-451-9055  
800-826-2873  
E-mail: [foxmarco@pacbell.net](mailto:foxmarco@pacbell.net)  
Contact: Charlie Barker

### CANADA DISTRIBUTORS

#### Canada – East

Eastern Marine Systems, Inc.  
12-A Leslie Street  
Toronto, Ontario M4M 3H7  
Tel: 416-465-1668  
888-764-1111  
Fax: 416-465-2098  
E-mail: [info@eastmar.com](mailto:info@eastmar.com)  
Contact: Paul Gales

#### Canada – West

Western Marine Company  
1494 Powell Street  
Vancouver, BC V5L 5B5  
Tel: 604-253-7721  
800-663-0600  
Fax: 604-253-2656  
800-663-6790  
E-mail: [sales@westernmarine.com](mailto:sales@westernmarine.com)  
Contact: Bill Falk

## **MANUFACTURER'S TWO-YEAR AND TEN-YEAR LIMITED WARRANTIES**

Dometic Corporation warrants, to the original purchaser only, that this Traveler® gravity discharge toilet, if used for personal, family or household-like purposes, is free from defects in material and workmanship for a period of two (2) years from the date of purchase.

Dometic also warrants, to the original purchaser only, that the ceramic portion of the toilet bowl will not discolor, stain, scratch or craze for a period of ten (10) years if used for personal, family or household-like purposes, and is regularly cleaned as described in the product's owner's manual.

If this Dometic product is placed in commercial or business use, it will be warranted, to the original purchaser only, to be free of defects in material and workmanship for a period of ninety (90) days from the date of purchase.

Dometic reserves the right to replace or repair any part of this product that proves, upon inspection by Dometic, to be defective in material or workmanship. All labor and transportation costs or charges incidental to warranty service are to be borne by the purchaser-user.

### **EXCLUSIONS**

IN NO EVENT SHALL **DOMETIC** BE LIABLE FOR INCIDENTAL OR CONSEQUENTIAL DAMAGES, FOR DAMAGES RESULTING FROM IMPROPER INSTALLATION, OR FOR DAMAGES CAUSED BY NEGLIGENCE, ABUSE, ALTERATION, OR USE OF UNAUTHORIZED COMPONENTS. THIS INCLUDES FAILURES WHICH MAY RESULT FROM NOT FOLLOWING THE WINTERIZATION OR CLEANING PROCEDURES AS DESCRIBED IN THE OWNER'S MANUAL. ALL IMPLIED WARRANTIES, INCLUDING ANY IMPLIED WARRANTY OF MERCHANTABILITY OR FITNESS FOR ANY PARTICULAR PURPOSE, ARE LIMITED TO A PERIOD OF ONE (1) YEAR FROM DATE OF PURCHASE.

### **IMPLIED WARRANTIES**

No person is authorized to change, add to, or create any warranty or obligation other than that set forth herein.

Implied warranties, including those of merchantability and fitness for a particular purpose, are limited to one (1) year from the date of purchase for products used for personal, family or household-like purposes, and ninety (90) days from the date of purchase for products placed in commercial or business use.

### **OTHER RIGHTS**

Some states do not allow limitations on the duration of an implied warranty, and some states do not allow exclusions or limitations regarding incidental or consequential damages; so, the above limitations may not apply to you. This warranty gives you specific legal rights, and you may have other rights which vary from state to state.

To obtain warranty service, first contact your local dealer from whom you purchased this product.



*The first choice in marine and RV sanitation.*

#### **Dometic Corporation**

13128 State Rt 226, PO Box 38  
Big Prairie, OH 44611-0038 USA  
SeaLand Product Customer Service  
1-800-321-9886  
330-496-3211 (8:00 a.m.-5:00 p.m. ET)  
Fax: 330-496-3097

® Registered; ™ Trademark of Dometic Corporation  
® Bar Keepers Friend is a trademark of Servaas Laboratories.  
® Teflon is a registered trademark of Du Pont Co.  
© 2002 Dometic Corporation